

JOB _____
 LOCATION _____
 SUBMITTED TO _____
 SUBMITTAL PREPARED BY _____
 APPROVED BY _____
 DATE _____



Submittal Form Cleats

Quad Cleat

- DOM-QCLT125 & HDQC-PLUS125 are compatible with Dyn-O-Mate[®] J, Ductmate[™] 35, CL Ward[™] J, Ward Industries[™] J, Hardcast[™] flanges, TDC, TDF and TDX Connections, and is manufactured from 22 gauge steel.
- HDQCPLUS125 is recommended for high pressure, heavy duty transverse duct.
- HDQCXL125 is designed to fit wider TDF profiles and heavier gauge duct.
- PQCLT is rated UL94-V0. PVC Material is compliant to ASTM D1784.

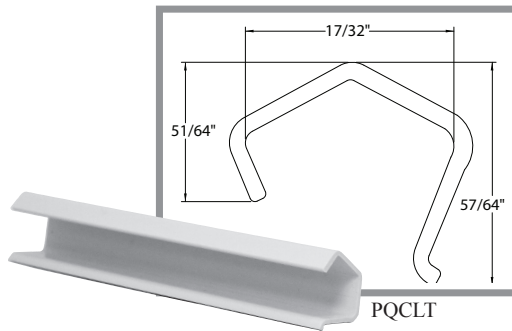
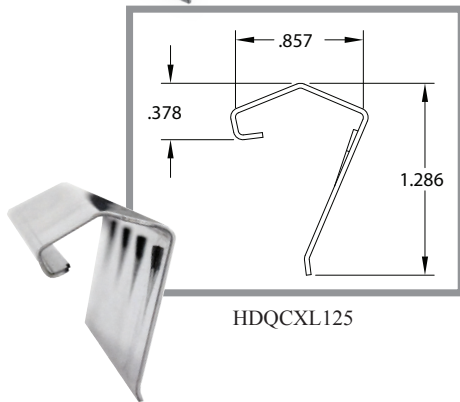
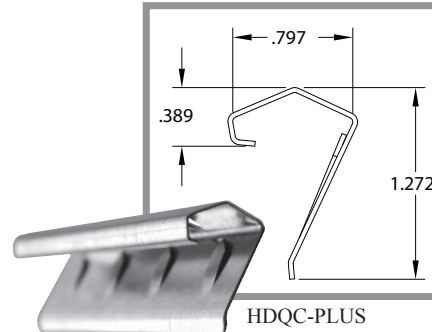
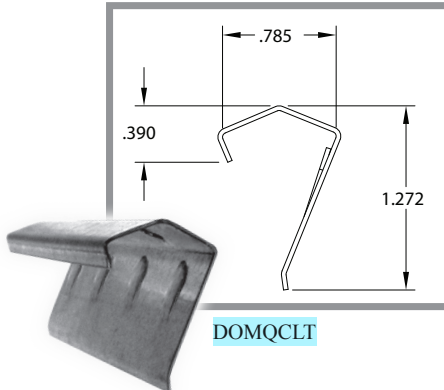

Item #	Code	Description
13096	DOMQCLT	6in Quad Cleat 22ga (1/2 box qty)
13100	QXCLT20-125	6in Quad Cleat 20ga (1/2 box qty)
13175	HDQCPLUS125	6in Heavy Duty Quad Cleat 22ga (1/2 box qty)
21228	DOMQCLTSS-25	6in Heavy Duty Stainless Steel Quad Cleat 24ga
13176	HDQCXL125	6in Heavy Duty Quad Cleat XL 22ga (1/2 box qty)
13108	PQCLT	6in Plastic Quad Cleat

See reverse side for Dyn-O-Mate & TDC/TDF Cleats

Installation Recommendations

- 1/2" to 2" sp - 1 piece on 24" centers
- 2" to 3" sp - 1 piece on 18" centers
- 4" to 6" sp - 1 piece on 12" centers
- Over 10" sp - continuous cleat

